

# INSTALLATION, OPERATION & SUPPORT MANUAL

**This page intentionally left blank**

# Table of Contents

List of Figures .....	3
List of Tables .....	3
1 INTRODUCTION .....	4
1.1 Introduction.....	4
1.2 SMAR <i>thatch</i> Mobile System, Hardware and Equipment .....	4
1.3 Intellectual Property Notices.....	6
1.4 Contact Information .....	6
1.5 Warranty .....	6
2 EQUIPMENT SAFETY COMPLIANCE .....	7
2.1 Safety .....	7
2.2 North American Emissions .....	7
2.3 Radio Module (Hatch-Mounted Sensor, Receiver Module and Telematics Module) .....	7
2.3.1 Unit Labeling: Sensor and Receiver Module.....	7
2.3.2 Unit Labeling: Telematics.....	8
2.4 Battery.....	9
3 GENERAL SAFETY GUIDELINES .....	10
3.1 Introduction.....	10
3.2 Safety Precautions.....	10
3.3 Definitions of Symbols .....	10
3.3.1 General Warning or Caution.....	10
3.3.2 Earth (Ground) Terminal .....	11
3.4 General Warnings and Cautions .....	11
4 INSTALLATION .....	13
4.1 Installation Training.....	13
4.2 Preparation .....	13
4.2.1 Power Requirements .....	13
4.2.2 System Operating Environment.....	14
4.3 Sensor Installation.....	14
4.3.1 Sensor Location and Orientation .....	14
4.3.2 Remove Existing Hatch or SMAR <i>thatch</i> Sensor .....	14
4.3.3 Install SMAR <i>thatch</i> Sensor .....	15
4.3.4 Battery Installation.....	17
4.4 Receiver Module Installation.....	18
4.5 In-Cab Display Installation .....	19
4.5.1 In-Cab Display .....	19
4.5.1.1 Universal mounting bracket.....	19
4.5.1.2 Panel Mounting.....	20
4.6 Battery Charger.....	20
4.7 Telematics Module Installation.....	20
4.8 Wiring .....	22
4.8.1 Wiring DC Power .....	22
4.8.2 Wiring CAN Bus.....	22
4.8.3 Advanced Receiver Connections .....	25
4.8.3.1 Install Hydraulic Pressure Sensor (Optional Equipment).....	25

4.8.3.2	Install SMARThatch Water Meter (Optional Equipment).....	26
4.9	Configuration Settings .....	27
4.9.1	Sensor-to-Receiver Wireless Pairing .....	27
4.9.2	Telematics Configuration and Activation .....	28
5	OPERATION .....	29
5.1	Instruction for Use .....	29
5.2	Operating Controls.....	29
5.3	In-Cab Display .....	29
5.3.1	Select Display Temperature Units .....	31
5.3.2	Adjust Display Backlight.....	31
5.4	Battery Charger .....	32
5.5	Web Portal .....	32
5.6	Telematics Modem LED.....	32
6	MAINTENANCE .....	33
6.1	Cleaning .....	33
6.2	Preventative Maintenance.....	33
6.2.1	General Maintenance .....	33
6.2.2	Inspection of the Nut Plate.....	33
6.2.3	Inspection of Sensor Face .....	34
6.3	Fuse Replacement (Truck Fuse Panel or Display Option 2).....	34
6.4	Battery .....	34
6.4.1	Disposal.....	34
	APPENDIX A - SMARThatch SPECIFICATIONS .....	35
A2	Fuse Protection.....	35
A3	Operating Temperature Range .....	35
A4	Storage Temperature Range.....	36
A6	Receiver Module Dimensional Envelope .....	37
A7	Display Dimensional Envelope (Option 1).....	38
A8	Altitude Limits .....	39
A9	Humidity Limits.....	39
A10	Degree of Protection .....	39
A11	Pollution Degree .....	39
A12	Area Classification.....	39
	APPENDIX B - Installation Record .....	40
	APPENDIX C – LED Status for Modes of Operation.....	41
	APPENDIX D – Panel Mounting .....	43

## List of Figures

Figure 1: Hatch-Mounted Sensor.....	5
Figure 2: Receiver Module .....	5
Figure 3: In-Cab Display.....	5
Figure 4: General Warning or Caution Symbol .....	10
Figure 5: Earth (Ground) Terminal Symbol.....	11
Figure 6: Label Indicating Proper Sensor Orientation .....	14
Figure 7: Heavy Weight Warning Symbol .....	15
Figure 8: Bottom Retaining Bolt Installed.....	15
Figure 9: SMARThatch Sensor Lifted into Position.....	16
Figure 10: Installed SMARThatch Sensor.....	16
Figure 11: Battery Cover Installed, and Removed Showing Battery Compartment .....	17
Figure 12: Battery Charge Indicator Showing Full Charge and Battery Terminals .....	17
Figure 13: Receiver Module Mounted to Back of Truck Cab.....	18
Figure 14: In-Cab Display with Universal Mounting Bracket .....	19
Figure 15: Universal Mounting Bracket Mounting Holes .....	19
Figure 16: Battery Charger .....	20
Figure 17: Telematics Module label with serial number .....	21
Figure 18: Standard Receiver Wiring Diagram .....	23
Figure 19: Advanced Receiver Wiring Diagram .....	24
Figure 20: Hydraulic Pressure Sensor Installed.....	26
Figure 21: Installed Water Meter .....	27
Figure 22: Sensor Pairing Button and LED inside battery compartment .....	28
Figure 23: Receiver Module Pairing Button and LED.....	28
Figure 24: Display Pushbuttons.....	29
Figure 25: In-Cab Display (Measuring) .....	30
Figure 26: In-Cab Display (SMARThatch Sensor Initialization).....	30
Figure 27: In-Cab Display (Depleted Battery or Power-Saving Mode) .....	31
Figure 28: Display Main Menu .....	31

## List of Tables

Table 1 System Operating Temperatures.....	14
Table 2: Telematics Module antenna connections.....	21

# 1 INTRODUCTION

---

## 1.1 Introduction

CiDRA Concrete's SMART*hatch* System is the first and only device to continuously measure and report the air content of fresh concrete in a truck mixer drum while being transported from batch plant to job site.

This manual covers the basic installation, setup, operation and maintenance of the SMART*hatch* System.

In all cases, local safety and operating practices take precedence over the information contained within this document.

## 1.2 SMART*hatch* Mobile System, Hardware and Equipment

The SMART*hatch* System hardware consists of a drum-mounted sensor, chassis-mounted receiver module, in-cab mounted display, cellular telematics module, battery charger and associated cables/connectors.

The SMART*hatch* sensor is mounted to a hatch adapter panel that replaces the existing drum access hatch as shown in Figure 1. Numerous hatch adapter panels are available to fit a variety of different truck mixer drum styles.

The SMART*hatch* sensor is powered by a rechargeable lithium-ion battery and communicates wirelessly to the SMART*hatch* receiver module which is mounted on the back of the truck cab or to the truck frame as shown in Figure 2.

The SMART*hatch* in-cab display shows concrete air content (%), concrete temperature (°F or °C), drum speed (rpm) and sensor battery charge level (% remaining) as shown in Figure 3.

The SMART*hatch* telematics module uses cellular communication to transmit measured data to a secure cloud server where it can be accessed through web-based portal or through an API.

The SMART*hatch* battery charger is located inside the truck cab and is powered by the truck 12 VDC power.

*Note: The SMART*hatch* sensor housing is made of hardened material that is well suited for the high abrasion environment inside a concrete mixer. However, to prevent damage that would require sensor replacement, care must be taken not to strike the face with a jackhammer, chisel, etc.*

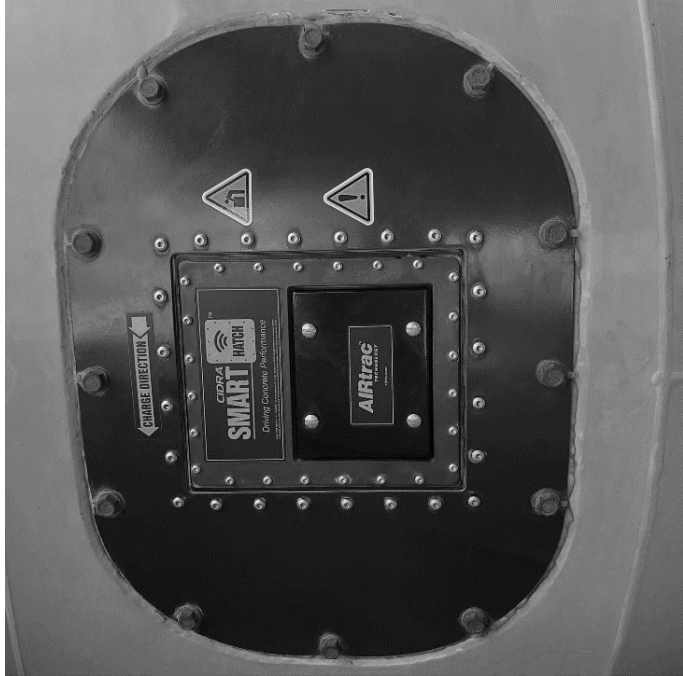

Figure 1: Hatch-Mounted Sensor



Figure 2: Receiver Module

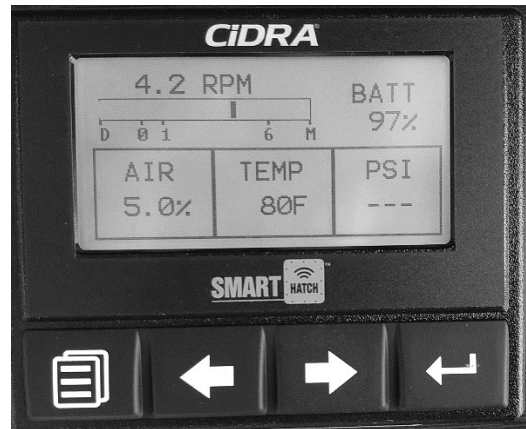

Figure 3: In-Cab Display

## 1.3 Intellectual Property Notices

SMART*hatch* Measurement Products may be covered by one or more of the following granted U.S. Patent(s):

6,354,147; 6,424,872; 6,435,030; 6,443,226; 6,587,798; 6,594,530;  
6,601,458; 6,609,069; 6,691,584; 6,732,575; 6,813,962; 6,862,920;  
6,889,562; 6,988,411; 7,032,432; 7,058,549; 7,062,976; 7,086,278;  
7,110,893; 7,121,152; 7,127,360; 7,134,320; 7,139,667; 7,146,864;  
7,150,202; 7,152,003; 7,152,460; 7,165,464; 7,171,315; 7,181,955;  
7,197,942; 7,253,742; 7,261,002; 7,275,421; 7,295,933; 7,308,820;  
7,322,245; 7,322,251; 7,328,113; 7,330,797; 7,337,075; 7,340,353;  
7,343,818; 7,343,820; 7,359,803; 7,363,800; 7,367,239; 7,367,240;  
7,379,828; 7,389,687; 7,400,985; 7,426,852; 7,437,946; 7,440,873;  
7,454,981; 7,474,966; 7,503,227; 7,516,024; 7,526,966; 7,571,633;  
7,587,948; 7,596,987; 7,617,716; 7,657,392; 7,672,794; 7,673,524;  
7,690,266; 7,725,270; 7,752,918; 7,793,555; 7,810,400; 7,882,750;  
7,962,293; 7,963,175; 9,169,158; 9,977,007; 10,088,454; 10,156,547

Other patents are pending; see [www.CidraConcrete.com](http://www.CidraConcrete.com) for the latest listing of patents.

This manual is covered by U.S. and international copyright laws. No part of this manual may be reproduced, modified or transmitted in whole or in part in any form or by any means, electronic or mechanical, including photocopy, recording, or any information storage and retrieval system, without permission in writing from CiDRA Concrete Systems Inc.

Copyright © 2020 CiDRA Concrete Systems Inc., all rights reserved.

AIRtrac™ & SMART*hatch*™ logo are trademarks of CiDRA Concrete Systems Inc.

## 1.4 Contact Information

CiDRA Concrete Systems Inc.  
50 Barnes Park North  
Wallingford, CT, USA 06492  
Telephone: 1-203-265-0035  
1-877-243-7277 (US and Canada)  
Website: [www.CidraConcrete.com](http://www.CidraConcrete.com)  
Sales Support: [sales@CidraConcrete.com](mailto:sales@CidraConcrete.com)

### First-Line Technical Support:

1-203-626-3430, or email: [SMARThatchsupport@CidraConcrete.com](mailto:SMARThatchsupport@CidraConcrete.com)

## 1.5 Warranty

The terms and conditions, including warranty, of the purchase of SMART*hatch* Systems are outlined in the document entitled “SMART*hatch* System Master Services Agreement Terms and Conditions”.



## **2 EQUIPMENT SAFETY COMPLIANCE**

---

### **2.1 Safety**

This equipment is listed with TÜV Rheinland of North America, Inc., a nationally recognized testing laboratory, certified for ordinary location use per the following US, Canadian and European standards:  
UL/ 61010-1, CSA C22.2 No. 1010 and EN61010-1.

### **2.2 North American Emissions**

This equipment is compliant with Class A limits for radiated and conducted radio noise emissions, as defined in Subpart A of Part 15 of the FCC rules, as well as the requirements defined in ICES-003 for Canada.

This Class A digital apparatus complies with Canadian ICES-003.

Cet appareil numérique de la classe A est conforme à la norme NMB- 003 du Canada.

### **2.3 Radio Module (Hatch-Mounted Sensor, Receiver Module and Telematics Module)**

The radio modules in the sensor and receiver module are labeled with its own FCC ID and IC Certification Number. The FCC ID and IC certification numbers are not visible so a label referring to the enclosed module is provided. The final end product must be labeled in a visible area with the following, “Unit Labeling”, see below.

Any changes or modifications not expressly approved by CiDRA could void the user’s authority to operate the equipment.

#### **2.3.1 Unit Labeling: Sensor and Receiver Module**

FCC ID: MCQ-S2CTH

IC 1846A-S2CTH

This device complies with Section 15.19(a) of the FCC Rules, and ICES-003. Operation is subject to the following two conditions:

- (1) this device may not cause harmful interference, and
- (2) this device must accept any interference received, including interference that may cause undesired operation.

### 2.3.2 Unit Labeling: Telematics

The device contains FCC compliant markings, see marking on unit.

This device complies with Part 15 of the FCC Rules, Operation is subject to the following two conditions:

- (3) this device may not cause harmful interference, and
- (4) this device must accept any interference received, including interference that may cause undesired operation.

Le présent appareil est conforme aux CNR d'Industrie Canada applicables aux appareils radio exempts de licence. L'exploitation est autorisée aux deux conditions suivantes:

- (1) l'appareil ne doit pas produire de brouillage, et
- (2) l'utilisateur de l'appareil doit accepter tout brouillage radioélectrique subi, même si le brouillage est susceptible d'en compromettre le fonctionnement.

	<b>CAUTION RF EXPOSURE</b> <b>The external antenna(s) used for the Receiver and Telematics radio modules must provide a separation distance of at least 25 cm [10"] from all persons and antenna modules and must not be co-located or operating in conjunction with any other antenna or transmitter except in accordance with FCC's multi-transmitter policy.</b>
---	--

	<b>MISE EN GARDE RF EXPOSURE</b> <b>L'antenne (s) externe (s) utilisée (s) pour les modules radio récepteur et télématique doit ménager une distance de séparation d'au moins 25 cm [10 "] par rapport à toutes les personnes et tous les modules et ne doit pas être colocalisée ou utilisée en conjonction avec une autre antenne ou émetteur sauf en conformité avec la politique de la FCC relative aux multi-émetteurs.</b>
---	---

## 2.4 Battery

The SMART*hatch* battery communicates with the host or the charger through the System Management Bus (SMBus).

The SMART*hatch* battery is fully compliant to UL/CSA/IEC 62133.

Protection is provided for over-charge, over-discharge and short circuit.

For redundancy, passive safety devices have been integrated into the pack to protect against overcurrent and over-temperature, and secondary over-voltage has been implemented with a logic-fuse and controller.

	<p style="text-align: center;"><b>WARNING</b></p> <p><b>CHARGE ONLY WITH A SMBUS COMPLIANT LEVEL 2 OR 3 CHARGER. DO NOT HEAT ABOVE 80°C. DO NOT OPEN BATTERY, DISPOSE OF IN FIRE OR SHORT CIRCUIT - MAY IGNITE, EXPLODE, LEAK OR GET HOT CAUSING PERSONAL INJURY. REPLACE BATTERY WITH SAME PART NUMBER ONLY. USE OF ANOTHER BATTERY MAY PRESENT A RISK OF FIRE OR EXPLOSION. KEEP AWAY FROM CHILDREN</b></p>
---	---

	<p style="text-align: center;"><b>AVERTISSEMENT</b></p> <p><b>CHARGEZ UNIQUEMENT AVEC UN CHARGEUR DE NIVEAU 2 OU 3 CONFORME À SMBUS. NE CHALEZ PAS AU-DESSUS DE 80 ° C. NE PAS OUVRIR LA BATTERIE, LA JETER AU FEU OU SUR UN COURT-CIRCUIT - PEUT IGNIT, EXPLOSER, FUIR OU CAUSER UNE BLESSURE GRAVE CAUSE DE BLESSURES CORPORELLES. REMPLACER LA PILE PAR LE MEME NUMERO DE PIECE UNIQUEMENT. L'UTILISATION D'UNE AUTRE BATTERIE PEUT PRÉSENTER UN RISQUE D'INCENDIE OU D'EXPLOSION. GARDER LOIN DES ENFANTS</b></p>
---	---

# 3 GENERAL SAFETY GUIDELINES

---



## 3.1 Introduction

This manual is intended to be a general installation guide for the SMART*hatch* System. It is not intended to cover the installation details for every instance due to the wide variety of scenarios that may be encountered. In all cases, local safety and operating practices should take precedence over instructions contained within this manual.

The installer must be appropriately trained and have read this manual prior to installing and operating the SMART*hatch* System.

## 3.2 Safety Precautions

The following style of Warnings and Cautions are used throughout the manual to draw attention to information regarding personnel safety and equipment care. They are intended to supplement but not replace local or plant safety procedures.

	<p style="text-align: center;"><b>WARNING</b></p> <p>Situation has the potential to cause bodily injury.</p>
	<p style="text-align: center;"><b>CAUTION</b></p> <p>Situation has the potential to cause damage to property or equipment.</p>

## 3.3 Definitions of Symbols

The following terms and symbols are used in this document and on the SMART*hatch* where safety related issues occur.

### 3.3.1 General Warning or Caution

The Exclamation Symbol in Figure 4 appears in Warning and Caution tables throughout this document. This symbol designates an area where personal injury or damage to the equipment is possible.



*Figure 4: General Warning or Caution Symbol*

### 3.3.2 Earth (Ground) Terminal

The Earth (Ground) Terminal Symbol in Figure 5 appears on labels affixed to the SMART*hatch* Sensor and related hardware. This symbol identifies components that are part of the earth ground circuit.

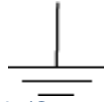

Figure 5: Earth (Ground) Terminal Symbol

### 3.4 General Warnings and Cautions

Observe these rules when operating or servicing this equipment:

- Prior to installation and operation of this equipment, the instruction manual must be read thoroughly.
- Trained personnel must carry out service on this equipment.
- Follow all warnings on the unit and in the operating instructions.
- This product should only be powered as described in the manual. Read the instructions for proper input voltage range selection.
- Ensure all power cables, and interface cables are properly routed to eliminate possible damage. Cable loom may be desirable to minimize potential damage.
- Modification or disassembly of any component by unauthorized personnel will void the system warranty.
- Follow static sensitive device precautions when servicing.
- Do not wear rings or wristwatches when servicing this equipment.
- To preserve the safety of this product, use only manufacturer specified replacement parts, do not perform unauthorized substitutions or modifications, and do not use the SMART*hatch* System in a manner not specified by manufacturer.
- For trouble-free, long-term performance, the SMART*hatch* System requires regular inspection and cleaning of the hatch-mounted sensor. When performing periodic inspections, take note of any damage to the hatch, sensor, electronics enclosures, and associated interface cables. If any damage is noted, take the appropriate corrective action depending on the situation – up to and including removal of the sensor from service until repairs have been performed. Contact CiDRA Concrete Customer Support (Section 1.4) for information regarding repairs and spare parts.
- The drum-mounted sensor with hatch adapter panel weighs approximately 56 lbs (25 kg). Two-person lift is required. Use extreme care and follow all procedures in this manual when installing and removing the sensor from the mixing drum.



- Battery Safety Handling
  - Avoid shorting the battery.
  - Do not immerse in water.
  - Do not disassemble or deform the battery.
  - Do not expose to or dispose of the battery in fire.
  - Avoid dropping and excessive physical shock or vibration.
  - Keep out of the reach of children.
  - Never use a battery that appears to have suffered abuse.
- Battery must be charged in appropriate charger only. Never use a modified or damaged charger.
- Store battery in a cool, dry and well-ventilated area, room temperature
- Battery disposal regulations vary for different countries. Dispose battery in accordance with local regulations.

# 4 INSTALLATION

---

## 4.1 Installation Training

Satisfactory completion of an installation training program provided by CiDRA Concrete is required prior to installing the SMART*hatch* system. Following purchase of SMART*hatch* services, the installation training program will generally work as follows:

- Customer designates installation personal and schedules initial installation.
- CiDRA provides remote and/or on-site installation assistance and training during the initial installation.
- The designated installation personal will receive a certificate of training completion and approval for installation of follow-on SMART*hatch* Systems

Contact CiDRA Concrete Customer Support for more information (Section 1.4).

## 4.2 Preparation

In addition to the warnings and cautions in this section, refer also to the General Safety Guidelines in Section 3.

### 4.2.1 Power Requirements

Ensure truck electrical power is turned off and truck battery disconnected prior to working on the receiver, display and telematics.

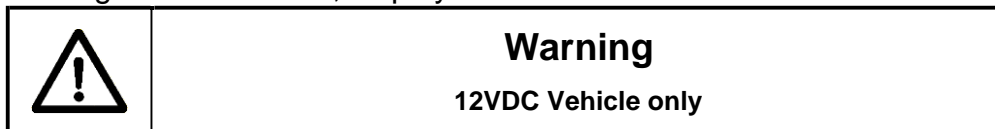

DC input power requires the following:

Receiver Module:

9 to 16VDC, 1 Watt, (for Trucks with 12VDC Battery only)

In-Cab Display:

9 to 16VDC, 1 Watt

Telematics Module:

9 to 16VDC, 7 Watts

An overcurrent protection device (fuse) must be installed on the supply side of the +12V ignition and +12V battery power inputs, with a fuse current rating of 10A to 20A.

## 4.2.2 System Operating Environment

* Sensor and Battery	-4°F to +140°F (-20°C to +60°C)
Receiver Module	-4°F to +140°F (-20°C to +60°C)
Display In-Cab	-4°F to +140°F (-20°C to +60°C)
Battery Charging	32°F to +113°F (0°C to +45°C)

\*Concrete temperature between 32°F to +122°F (0°C to +50°C)

*Table 1 System Operating Temperatures*

The SMART*hatch* sensor, receiver, and display are suitable for operation in 0 to 95% non-condensing humidity environments.

## 4.3 Sensor Installation

The following steps detail installation of the SMART*hatch* System.

### 4.3.1 Sensor Location and Orientation

The SMART*hatch* sensor is installed in place of the existing drum access hatch. For accurate air and temperature readings it is important that the sensor is installed in the proper orientation relative to the drum rotation direction. The sensor assembly has an orientation label that points in the direction of rotation when the drum is rotating in the charging direction (Figure 6).



*Figure 6: Label Indicating Proper Sensor Orientation*

### 4.3.2 Remove Existing Hatch or SMART*hatch* Sensor

Remove the existing mixer drum access hatch. Clean and inspect sealing surface and nut plate per drum manufacturer's recommended practices. It is very important that the nut plate is in good condition and therefore should be replaced if excessive wear or any defects are found, or if there is any concern that its mechanical integrity is compromised.



If an SMART*hatch* sensor is already installed, use caution when removing, as it is heavy (56 lbs / 25 kg) and can cause serious injury if mishandled or dropped. Two (2) people are required for removal.

Loosen all retaining bolts and leave several in place while prying the hatch free. Remove all bolts, except the bottom retaining bolt to help support the weight before the hatch is lifted off the drum. See Figure 8 for example of retaining bolt.



### 4.3.3 Install SMART $hatch$ Sensor

	<p style="text-align: center;"><b>Warning</b></p> <p><b>WARNING:</b> The SMART<math>hatch</math> Sensor is heavy (56 lbs / 25 kg) and can cause serious injury if mishandled or dropped. Two (2) people are required for installation and removal, see symbol below.</p>
---	--



*Figure 7: Heavy Weight Warning Symbol*

Install gasket or sealing compound following drum manufacturer's recommendations.

The SMART $hatch$  hatch adapter flange has slotted bolt holes on the top and the bottom. At the nut location of the bottom slotted hole, partially install a retaining bolt into the nut plate, engaging at least three threads and allowing at least 3/8-inch (9.5 mm) gap between the bolt head and the outer drum surface as shown in Figure 8.

With two (2) people, lift the SMART $hatch$  sensor into position and in the correct orientation. Slide the bottom slotted hole onto the installed bolt to help support the weight of the sensor during installation as shown in Figure 9.

Install the remaining retaining bolts and tighten following the drum manufacturer's recommended procedure.

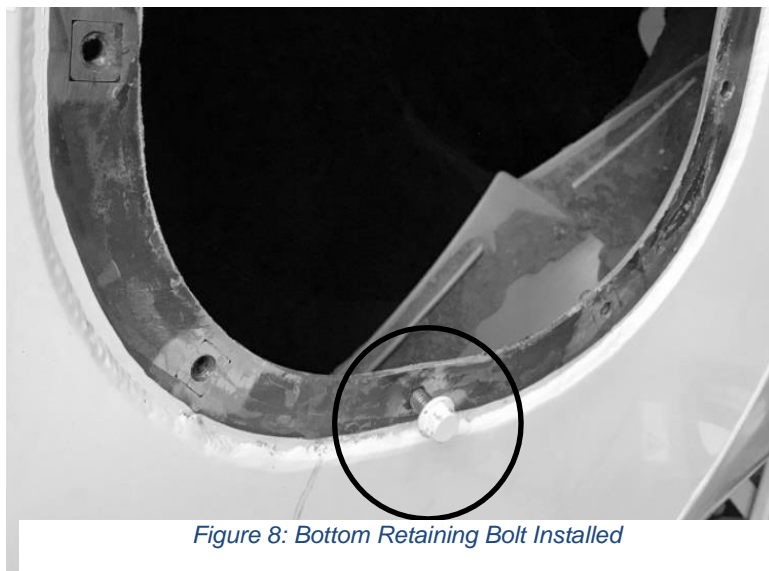

*Figure 8: Bottom Retaining Bolt Installed*



Figure 9: SMARThatch Sensor Lifted into Position

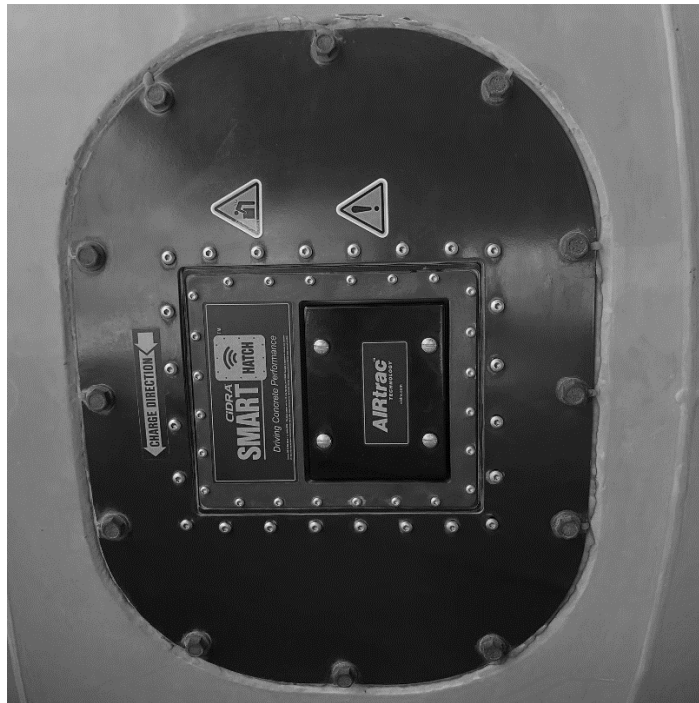

Figure 10: Installed SMARThatch Sensor

### 4.3.4 Battery Installation

Only batteries specified by CIDRA Concrete should be used in the SMART*hatch* sensor, CiDRA P/N 21809-01, 7.2VDC, 98Wh.

To replace the SMART*hatch* sensor battery, remove battery cover by loosening four (4) one-quarter turn screws (Figure 11), lift the battery cover off and remove the battery from the sensor.

Check that the battery charge indicator located on end of the replacement battery shows five bars indicating full charge (Figure 12). Line up the battery terminals and insert the battery terminal side first making sure it is fully engaged and secure. Replace battery cover and securely tighten four (4) one-quarter turn screws.

The spare battery may be stored in the battery charger, so it is always charged.

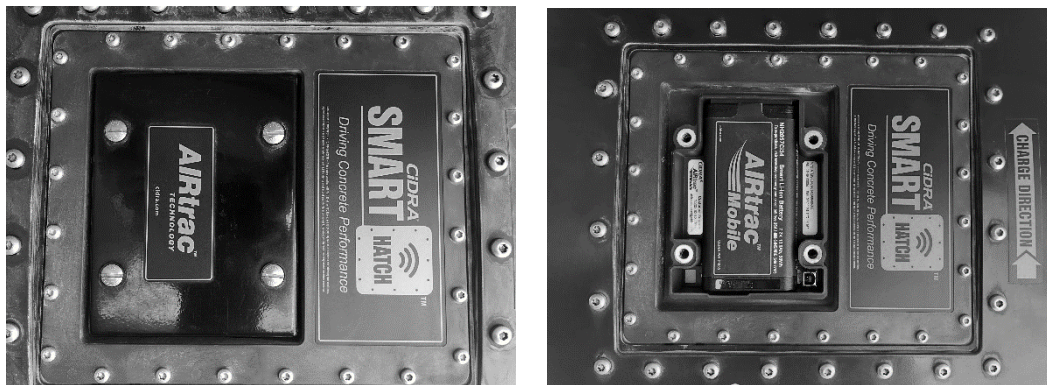



Figure 11: Battery Cover Installed, and Removed Showing Battery Compartment



Figure 12: Battery Charge Indicator Showing Full Charge and Battery Terminals

## 4.4 Receiver Module Installation

	<b>CAUTION</b> The receiver module must provide a separation distance of at least 25 cm [10"] from all persons and must not be co-located or operating in conjunction with any other antenna or transmitter except in accordance with FCC's multi-transmitter policy.
---	--

Determine a location for the receiver module where it can be mounted on a flat surface that has a clear line-of-site to the SMART<sup>hatch</sup> sensor on the drum. Avoid mounting where the wireless signal between the receiver module and the sensor might be blocked by a metal obstruction, for example the water tank or truck frame. Figure 13 shows an example mounting location.

The mounting location must also allow the 13 ft (4 m) receiver module cable to be routed to the inside of the truck cab to the area where the telematics module will be mounted.

Use self-tapping screws or equivalent to hold the receiver module securely in place.



*Figure 13: Receiver Module Mounted to Back of Truck Cab*

## 4.5 In-Cab Display Installation

Determine a location for the in-cab display where it is in clear view of the driver and will not obstruct the driver's view of the road and surroundings.

The mounting location must also allow the 13 ft (4 m) display cable to be routed inside the truck cab to the area where the telematics module will be mounted, so it is out of the way and will not create any safety hazards.

### 4.5.1 In-Cab Display

The display can be mounted using the universal mounting bracket (provided) or panel mounted. When installing the display cable, use the provide p-clip to strain relieve the cable.

#### 4.5.1.1 Universal mounting bracket

The mounting bracket can be rotated 180 degrees vertically or flipped 180 degrees from the position shown in Figure 14. For flexibility in mounting the display in the cab. There are 2 mounting holes for attaching the display as shown in Figure 15 (mounting screws not provided).

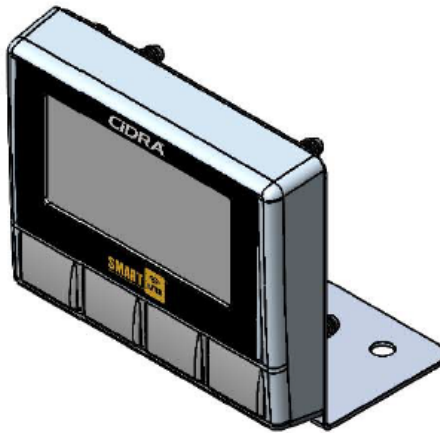

Figure 14: In-Cab Display with Universal Mounting Bracket

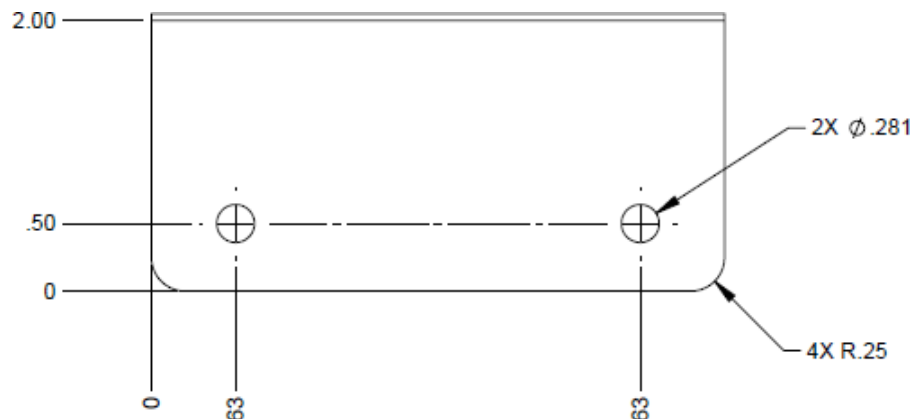

Figure 15: Universal Mounting Bracket Mounting Holes



#### 4.5.1.2 Panel Mounting

The display has four M6-1.0 studs for panel mounting. Panel cutout dimensions and a cutout template are provided in Appendix D at the end of this manual.

### 4.6 Battery Charger

The battery charger (Figure 16) should be mounted inside the truck cab where it is out of the way but accessible by the driver. The charger is supplied with a 12VDC plug for connecting to the truck power outlet.

The SMART*hatch* System is supplied with two batteries. While one is being used in the sensor the other may be stored in the battery charger, so it is always charged and ready for use.



Figure 16: Battery Charger

### 4.7 Telematics Module Installation

Determine a location for the telematics module inside the truck cab.

The mounting location must allow the 1 ft (0.3 m) telematics cable to be spliced to the free end of both the receiver and display cables.

Prior to mounting the receiver module, display and telematics module, verify the free end all cables can reach a common location. Also, use the form in APPENDIX B - Installation Record to record the telematics module serial number located on the back of the module (Figure 17) and truck identification number for each installed SMART*hatch* system.

Use self-tapping screws or equivalent to hold the telematics module securely in place (screws not provided).

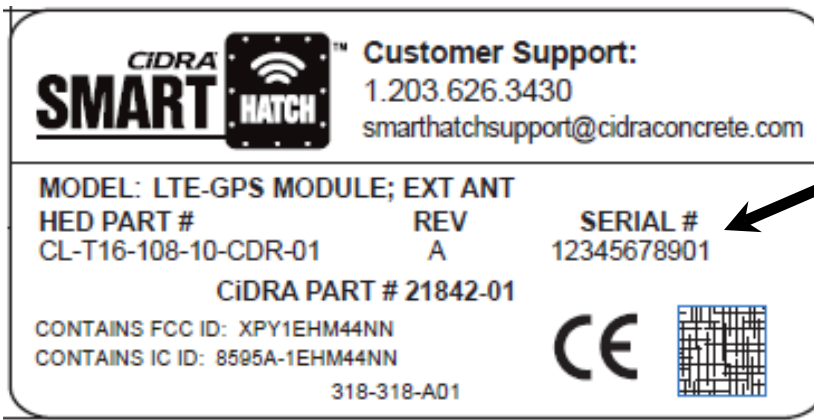



Figure 17: Telematics Module label with serial number

	<h3>CAUTION</h3> <p>The external antenna(s) used for the radio module must provide a separation distance of at least 25 cm [10"] from all persons and must not be co-located or operating in conjunction with any other antenna or transmitter except in accordance with FCC's multi-transmitter policy.</p>
---	--

Connect the cellular antenna cable connectors to the proper terminals on the outside of the telematics module as shown in Table 1, and torque to 7-10 in-lb (0.8-1.1 N-m). Mount the antenna high inside the truck cab away from any metal frames.

Telematics Module Terminal	Antenna Cable	Description
CELL M LTE 1	MIMO 1 LTE 1	Main cell antenna
CELL D LTE 2	MIMO 2 LTE 2	Diversity cell antenna
GNSS GPS	GPS	Global Positioning System

Table 2: Telematics Module antenna connections

## 4.8 Wiring

Securely attach cable connectors to receiver, in-cab display, and telematics module. Securely route all cables to a common location inside the cab, preferably close to fuse panel with truck electrical connections (+12V battery, +12V ignition switched and vehicle ground).

Use only power cables with copper conductors size 20 AWG minimum to 16 AWG maximum (0.82 mm<sup>2</sup> to 5.26 mm<sup>2</sup>). Due to temperatures in truck cabin, cable rated 176°F (80°C) or higher is recommended.

For standard systems equipped with CiDRA P/N:21718-0002 refer to Figure 18.

Advanced feature SMART*hatch* systems are capable of reading optional hydraulic pressure and/or water meter sensors and must be equipped with CiDRA P/N:21718-0003. For these systems refer to Figure 19.

Cut to length and strip individual wires as described in the following sections.

### 4.8.1 Wiring DC Power

An overcurrent protection device (fuse) must be installed on the supply side of the ignition switched and battery inputs, with a fuse current rating of 10A to 20A.

- Splice all three (3) yellow wires securely from the receiver, display and telematics cables together, then connect to vehicle ground.
- Splice all three (3) orange wires securely from the receiver, display and telematics cables together, then connect to fused +12V ignition switched.
- Connect one (1) red wire from telematics cable to fused +12V battery

### 4.8.2 Wiring CAN Bus

Refer to CAN Bus connections shown in Figure 18 or Figure 19 as appropriate.

- Splice all three (3) blue wires securely (CAN Hi) from the receiver, display and telematics cables together.
- Splice all three (3) white wires securely (CAN Lo) from the receiver, display and telematics cables together.



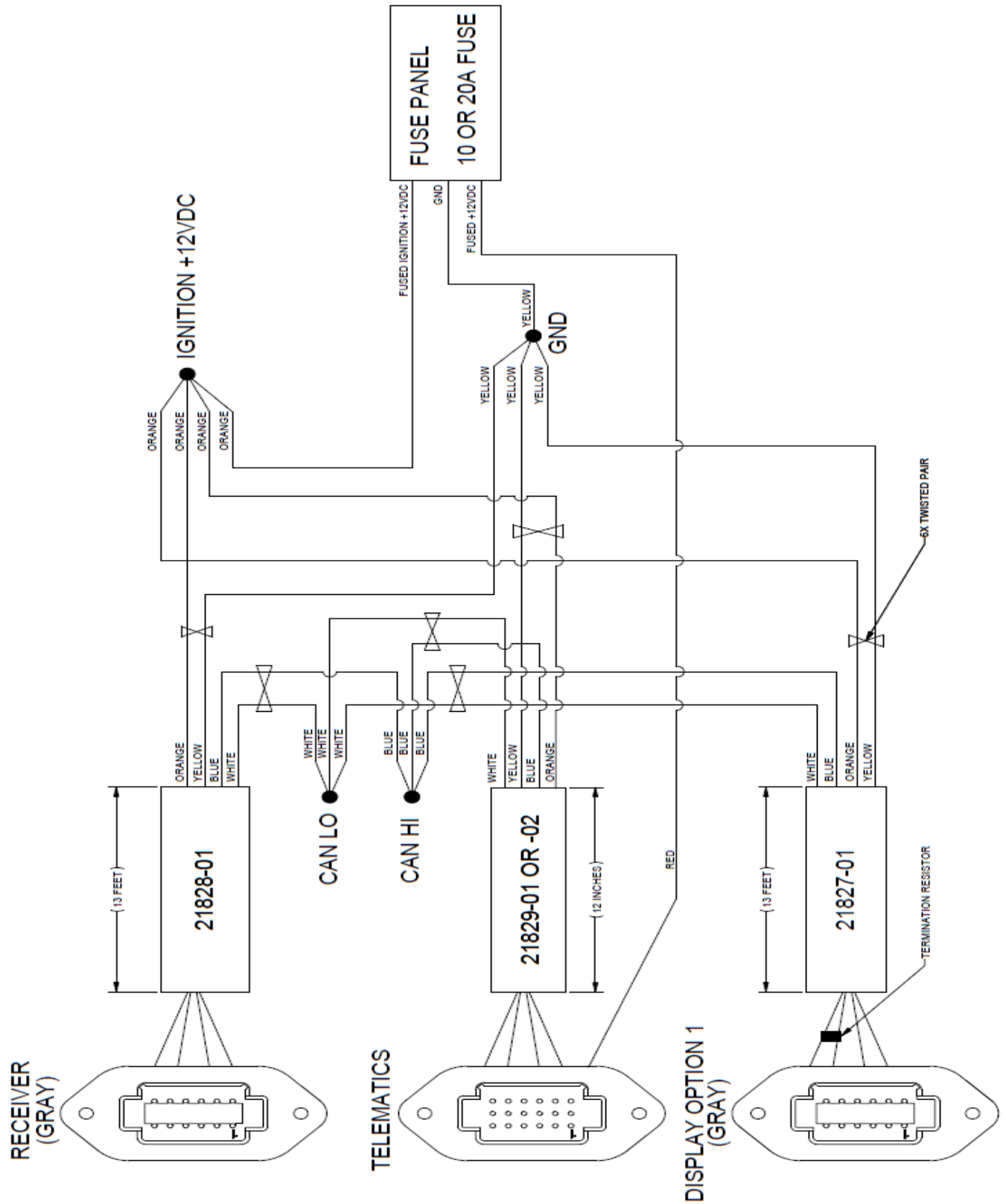

Figure 18: Standard Receiver Wiring Diagram

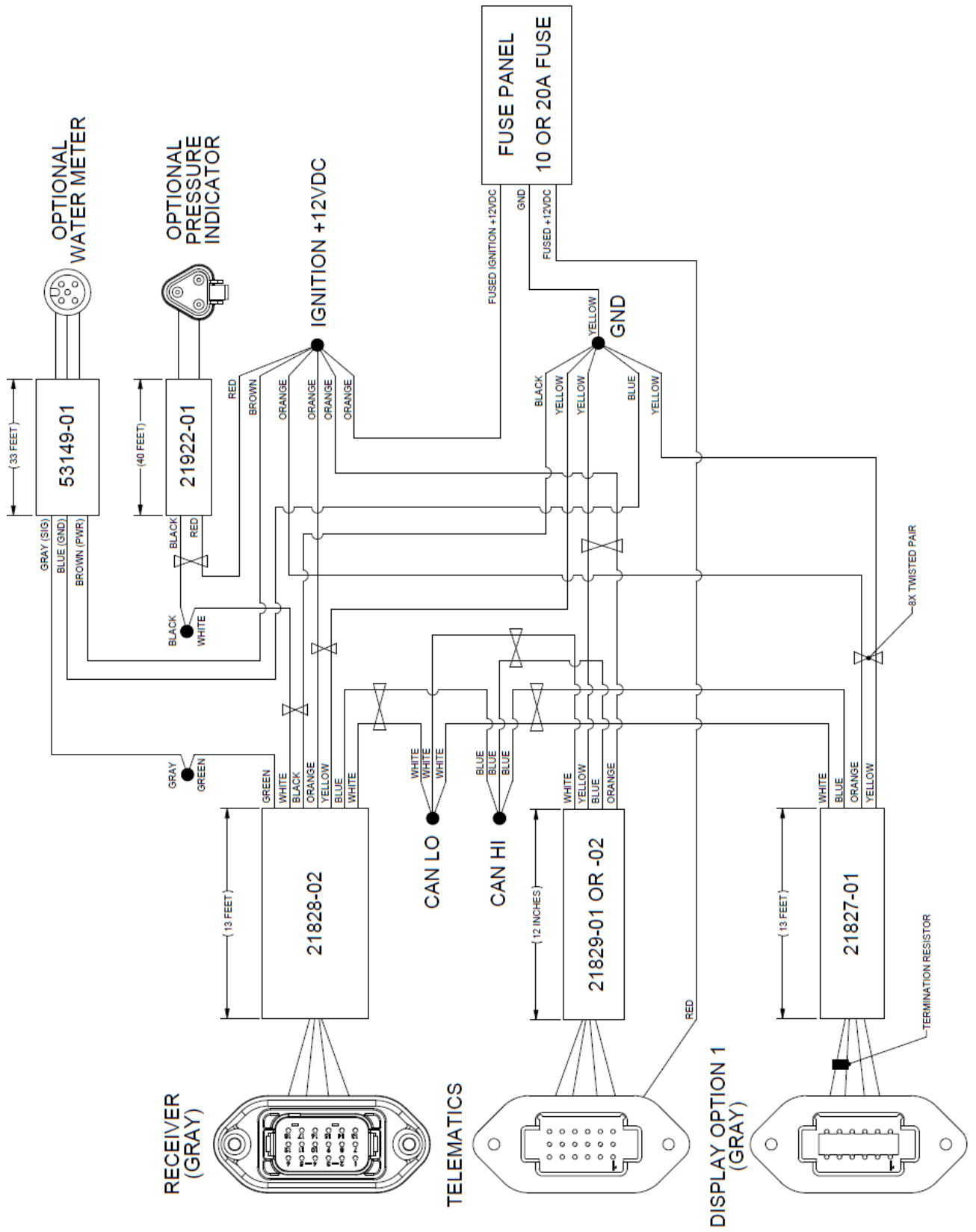

Figure 19: Advanced Receiver Wiring Diagram

### 4.8.3 Advanced Receiver Connections

Receiver connections: ANA1, ANA2, ANA3, DIGITAL1, DIGITAL2, and 485 have been designed to operate while maintaining safety rated conditions.

- ANA1 HI/LO is a current input.
- ANA2 HI/LO is a differential voltage input (a resistor is needed external to the box to sense current).
- ANA3 HI/LO can either be one differential voltage input or 2 digital I/Os (individually configurable as digital inputs or digital outputs).
- DIGITAL1 and DIGITAL2 are digital I/Os (individually configurable as digital inputs or digital outputs).

Note: Digital I/Os default to inputs. When configured as outputs, they are switches to ground thru a 100-ohm resistor (so the states are either open or “ground”).

For Analog Current Inputs: the max rated current is +100mA

For Analog Voltage inputs: the max rated differential voltage (HI to LO) is +12.5V

For the Digital Inputs:

- Logic ‘0’ is or any voltage between 0V and 2V (switch closure to GND).
- Logic ‘1’ is and open input or any voltage between 3V and 30V.

For the Digital Outputs:

- Logic ‘0’ is 100 Ohms to GND with the max allowed current sink is 25mA
- Logic ‘1’ is an open circuit with the max voltage range of 0V to 30V.

#### 4.8.3.1 Install Hydraulic Pressure Sensor (Optional Equipment)

Refer to Figure 19 Advanced Receiver Wiring Diagram:

The **Hydraulic Pressure Sensor** is an advanced feature option that requires Receiver Module CiDRA P/N:21718-0003 and Receiver Cable CiDRA P/N:21828-02.

For Hydraulic Pressure (HP) installation procedure see listed steps below.

- Make sure Drum is not rotating, and hydraulic pressure (HP) is de-energized (Existing analog HP Gauge is reading 0 PSI).
- Disconnect existing female fitting from either the Pump end or Gauge end of the Hydraulic line. (Figure 20 shows the HP installed at the Pump end.)
- Connect CiDRA supplied fitting (or equivalent) in between the disconnected section of hydraulic hose.
- Securely tighten all fittings.

- Ensure Pressure sensor fitting is securely tightened to ensure O-ring is properly compressed. Note: lube the O-ring to avoid tearing.
- Connect wire harness into the pressure sensor.
- Route the cable into the cab to the Receiver/Modem/Power junction. Secure the cabling appropriately along the way.
- Connect pressure sensor wires to switched 12V power, ground, and Receiver analog inputs as shown in Figure 19.

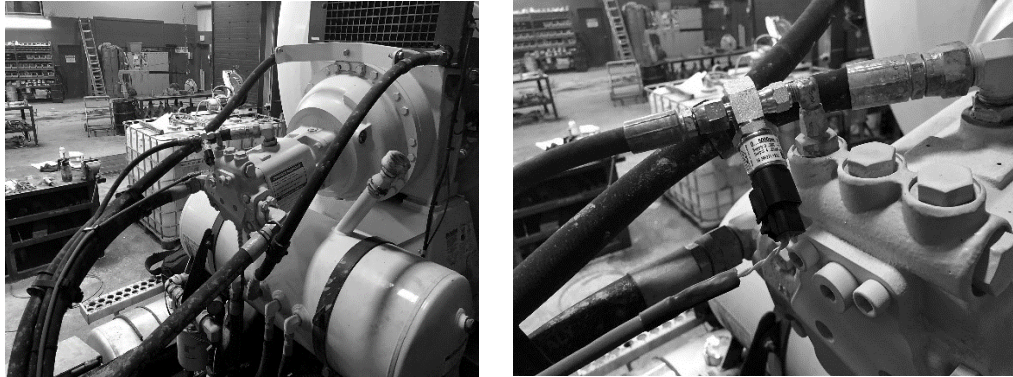

*Figure 20: Hydraulic Pressure Sensor Installed*

#### **4.8.3.2 Install SMARThatch Water Meter (Optional Equipment)**

Refer to Figure 19 Advanced Receiver Wiring Diagram:

The **SMARThatch Water Meter** is an advanced feature option that requires Receiver Module CiDRA P/N:21718-0003 and Receiver Cable CiDRA P/N:21828-02.

For Water Meter installation procedure see listed steps below.

- Make sure the water line feeding into the drum is drained.
- Cut out a section of the water feed line large enough to fit the supplied water meter.
- Install the two supplied 1"NPT to 1" barb fittings into the water meter inlet and outlet. If customer equipment is not 1" tubing, then appropriate customer supplied fitting adapters must be used. When threading into the flow meter use Teflon tape and turn 1.5 turns past hand tight. Avoid over-tightening which could damage the flow meter.
- Install the water meter using the supplied hose clamps and secure the water meter to the truck frame as shown in Figure 21. Pay attention to and follow the flow direction marking on the water meter.
- Connect wire harness to the water meter and route the cable into the cab to the Receiver/Modem/Power junction. Secure the cabling appropriately along the way.
- Connect the water meter wires to switched 12V power, ground, and Receiver analog inputs as shown in Figure 19.



Figure 21: Installed Water Meter

## 4.9 Configuration Settings

### 4.9.1 Sensor-to-Receiver Wireless Pairing

Once installed, the SMARThatch sensor must be uniquely paired to the receiver module.

- 1) Install sensor battery and turn on truck power.
- 2) The sensor pair button is located in battery compartment next to the battery terminals. Remove the battery cover by loosening four (4) one-quarter turn screws and lift the battery cover off. Press and hold button sensor pair button for a minimum of two (2) seconds (Figure 22).
- 3) The receiver module pair button is located on the side of the receiver housing. Press and hold receiver pair button for a minimum of two (2) seconds (Figure 23).
- 4) Once pairing is started, LED's on sensor and receiver will blink green at 3X per second until successful pairing is complete. The LED's will then light solid green for 2.5 seconds indicating successful pairing.
- 5) If after 30 seconds the LED's do not light solid pairing was not successful. Repeat the pairing process starting at step 1 above.

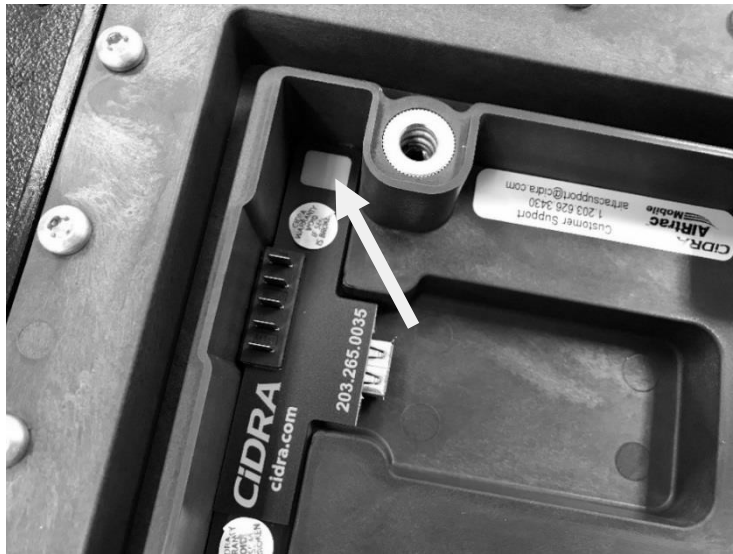

Figure 22: Sensor Pairing Button and LED inside battery compartment  
(battery removed for clarity, but must be installed during pairing)



Figure 23: Receiver Module Pairing Button and LED

#### 4.9.2 Telematics Configuration and Activation

The telematics module must be configured so it is uniquely associated with the truck that it is installed, based on the serial number and truck identification recorded during installation (Section 4.7).

Contact CiDRA Concrete Customer Support (Section 1.4) for assistance with configuration and activation of the telematics module.



# 5 OPERATION

---

## 5.1 Instruction for Use

Once the SMART*hatch* is installed and operational, no operator intervention except replacing the battery in the hatch-mounted sensor is required (see Section 4.3.4). The in-cab display shows the battery status. Only trained service personnel should access the SMART*hatch* system.

## 5.2 Operating Controls

The SMART*hatch* system does not contain any operator controls and automatically provides data for drum rotation, concrete temperature, air % and battery charge level provided the following conditions are met:

- A minimum of approximately two (2) yards of concrete in the drum
- The drum is rotating in the charge direction between 0.5 rpm and 6 rpm
- The concrete slump is greater than approximately 2 inches
- The concrete water-to-cement ratio (w/c) is greater than approximately 0.3

Once the above conditions are met, the SMART*hatch* sensor will begin initialization. Initialization is complete when the drum is rotated in the charge direction, between 0.5 and 6 rpm, for eight (8) revolutions. Once the eight (8) revolutions are achieved the concrete air percent and temperature will be displayed.

## 5.3 In-Cab Display

The in-cab display shows concrete air content (%), concrete temperature (°F or °C), drum speed (rpm) and sensor battery charge level (% remaining).

The In-Cab Display has four pushbuttons as shown in Figure 24.



*Figure 24: Display Pushbuttons*

Press left-most button to display the menu. Press the left/right arrow buttons to navigate through a menu. Press the right-most return key to select a highlighted menu item. At any time when the menu is displayed press the left-most button to exit the menu without making a selection.

During normal operation, when conditions meet the requirements of Section 5.2, the following information will be displayed to the driver (Figure 25):

- Air Content (% by volume)
- Concrete temperature (°F or °C)
- Drum speed (RPM) and direction (positive rpm is charge direction; negative rpm is discharge direction)
- Battery charge level (% remaining)
- Hydraulic Pressure if optionally equipped.



Figure 25: In-Cab Display (Measuring)

If conditions do not meet the requirements of Section 5.2, the display will show the following (Figure 26):

- Number of drum revolutions remaining to complete SMART<sup>hatch</sup> sensor initialization and begin air content measurement
- Drum speed and direction
- Battery charge level
- Hydraulic Pressure if optionally equipped.



Figure 26: In-Cab Display (SMART<sup>hatch</sup> Sensor Initialization)



If the SMART*hatch* sensor battery is depleted (Section 4.3.4), pairing is not established, or the SMART*hatch* sensor has entered a power-saving “sleep” mode (due to several minutes of no drum rotation) the display will show the following (Figure 27).



Figure 27: In-Cab Display (Depleted Battery or Power-Saving Mode)

### 5.3.1 Select Display Temperature Units

The concrete temperature can be displayed in either degrees Fahrenheit (°F) or degrees Celsius (°C). To select which units are used:

- 1) Press the left-most button to display the main menu (Figure 28).

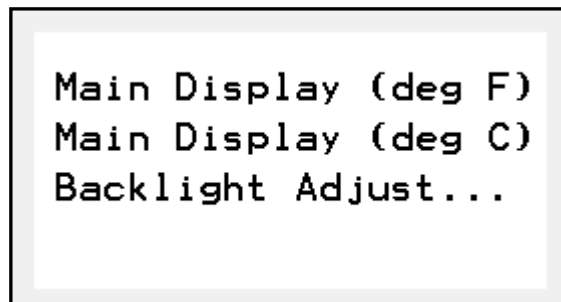

Figure 28: Display Main Menu

- 2) Use the left/right arrow buttons to highlight **Mai n Di spl ay (deg F)** or **Mai n Di spl ay (deg C)**.
- 3) Press the right-most button to select and return the main display page.

### 5.3.2 Adjust Display Backlight

The in-cab backlight can be adjusted as desired. To adjust the backlight:

- 1) Press the left-most button to display the main menu (Figure 27).
- 2) Use the left/right arrow buttons to highlight **Backl i gh t Adj ust....**

- 3) Press the right-most button to open the backlight adjust menu.
- 4) Adjust the backlight colors as desired.
- 5) When finished, use the left/right arrow keys to highlight **Save** and **Exit** to save changes and exit or **Exit** to discard any changes.
- 6) Press the right-most button to select and return the main display page.

## **5.4 Battery Charger**

The SMART*hatch* System is supplied with two batteries. While one is being used in the sensor the other should be stored in the battery charger so it is always charged and ready for use.

To charge the battery, insert it in the charger terminal end first. The charge indicator will blink indicating charging is taking place. When fully charged, the charge indicator will show five solid bars. The battery can be stored in the charger until ready for use.

## **5.5 Web Portal**

The SMART*hatch* web portal provides real-time and archived data from the SMART*hatch* system. The portal is designed to organize all trucks in your fleet for quick user access. The web portal address is <https://smarthatch.canect.io/>

Training on setup and use of the web portal is provided separately by CiDRA Concrete Customer Support.

## **5.6 Telematics Modem LED**

For a breakdown of LED modes of operation for the telematics module Status, GPS, and Cell refer to Appendix C.

# 6 MAINTENANCE

---

## 6.1 Cleaning

Note: The SMART*hatch* sensor face is made of a hardened material that is well-suited for the high abrasion concrete mixer environment.

However, to prevent damage that would require sensor replacement, extreme care must be taken not to strike the face with a hammer, chisel, etc.

For proper operation and long-term service, the SMART*hatch* sensor face must be kept clean and free from any buildup. It is important the sensor face is thoroughly rinsed with water during routine mixer cleaning, prior to the concrete curing and build-up.

Should a small amount of build-up occur on the face of the sensor, the drum can be loaded with  $\frac{3}{4}$ " aggregate and water, then run at full charge to scrub the concrete off the sensor face.

## 6.2 Preventative Maintenance

### 6.2.1 General Maintenance

When performing periodic inspection of the drum and truck, take note of any damage to the sensor, receiver and associated cables. If any noted damage indicates that the protection of the electronics is compromised or that compromise is imminent, or if the cable damage suggests that cable electrical shorts or opens are imminent, then take the appropriate corrective action depending on the situation – up to and including removal of the affected component from service until repairs have been performed. Contact CiDRA Concrete Customer Support regarding service, repairs and spare parts (Section 1.4).

### 6.2.2 Inspection of the Nut Plate

The hatch nut plate is a wear item. It should be inspected according to the drum manufacturers recommended procedures and schedule. If it is determined that the wear is excessive, it must be repaired. Remove the SMART*hatch* sensor from the drum prior to servicing the nut plate.

### 6.2.3 Inspection of Sensor Face

During routine drum “chipping” the SMART*hatch* sensor should be removed to avoid damage. At this time, the sensor face should be inspected for any signs of damage, wear or concrete build up. Any damage or excessive wear should be reported to CiDRA Concrete Customer Support (Section 1.4).

Concrete build-up can be carefully cleaned off the sensor casting surface; however, hammers, chisels, etc. should not be used on the elastomeric surfaces on the sensor face.

### 6.3 Fuse Replacement (Truck Fuse Panel or Display Option 2)

In the event that an electrical fault causes a fuse to open, the operator should notify trained service personnel to assess the cause of the fault. Fuse replacement is not intended to be performed by the operator and should be performed only by trained service personnel

The service personnel may, when it is safe to do so, replace the fuse using the proper replacement fuse.

	<p style="text-align: center;"><b>CAUTION</b></p> <p><b>Fuse replacement is not intended to be performed by the operator and should be performed by trained service personnel</b></p>
--	---

### 6.4 Battery

#### 6.4.1 Disposal

The “smart” lithium-ion (Li-Ion) battery that powers the SMART*hatch* sensor is designed to provide several years of service under typical operating conditions. Over time they will eventually begin to lose capacity and when no longer holding a sufficient charge they should be replaced. Contact CiDRA Concrete Customer Support (Section 1.4) or the battery manufacturer to purchase new batteries.

Do not return used batteries to CiDRA Concrete Systems. They should be disposed of locally in accordance with local and state regulations.



# APPENDIX A - SMARThatch SPECIFICATIONS

## A1 Power Requirements

---

Sensor (drum mounted): Rechargeable Li-ion Battery

Nominal 7.2VDC, 4 Watts

Receiver Module:

9 to 16 VDC, 1 Watt, for Trucks with 12VDC Battery only

In-Cab Display:

9 to 16VDC, 1 Watt

Telematics Module:

For Reference only 9 to 32VDC, 7 Watts

## A2 Fuse Protection

---

The receiver module, display Option 1 and telematics module do not include a fuse. An overcurrent protection device (fuse) must be installed on the supply side of the +12V Ignition and +12V Battery power inputs, with a fuse current rating of 10A to 20A.

For display Option 2, cabling includes Mini Blade Fuse in an inline splash-proof fuse holder. The fuse used is Littelfuse 0297002H (2A, 32V rated, Time blow fuse).

## A3 Operating Temperature Range

---

The sensor and receiver electronics are rated for indoor and outdoor use. The display is rated for indoor use only.

* Sensor Unit and Battery	-4°F to +140°F (-20°C to +60°C)
Receiver Module	-4°F to +140°F (-20°C to +60°C)
Display In-Cab	-4°F to +140°F (-20°C to +60°C)
Battery Charging	32°F to +113°F (0°C to +45°C)

\* Concrete between 32°F to +122°F (0°C to +50°C)

## A4 Storage Temperature Range

Sensor Unit	-40°F to +158°F (-40°C to +70°C)
Battery	-40°F to +158°F (-40°C to +70°C)
Receiver Module	-40°F to +158°F (-40°C to +70°C)
Display In-Cab	-40°F to +158°F (-40°C to +70°C)

	<p><b>CAUTION</b></p> <p>The battery packs should be stored in an environment with low humidity, free from corrosive gas at a recommended temperature range &lt;70°F (21°C). Extended exposure to temperatures above 113°F (45°C) could degrade battery performance and life.</p>
---	---

## A5 Sensor Dimensional Envelope

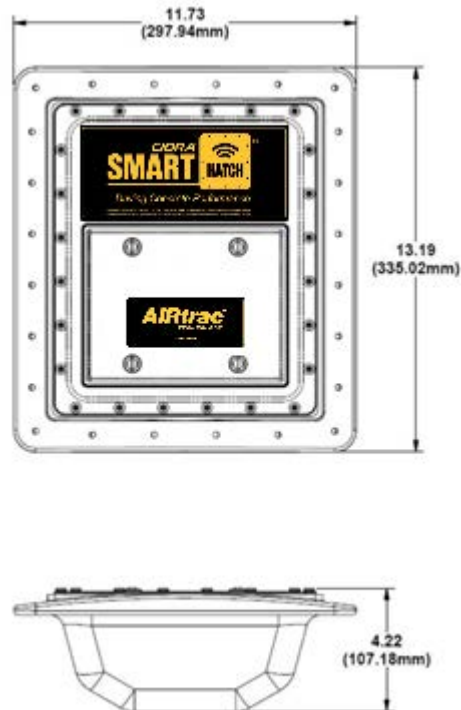

Weight: 39 lbs (17.6 kg)

# Receiver Module Dimensional Envelope

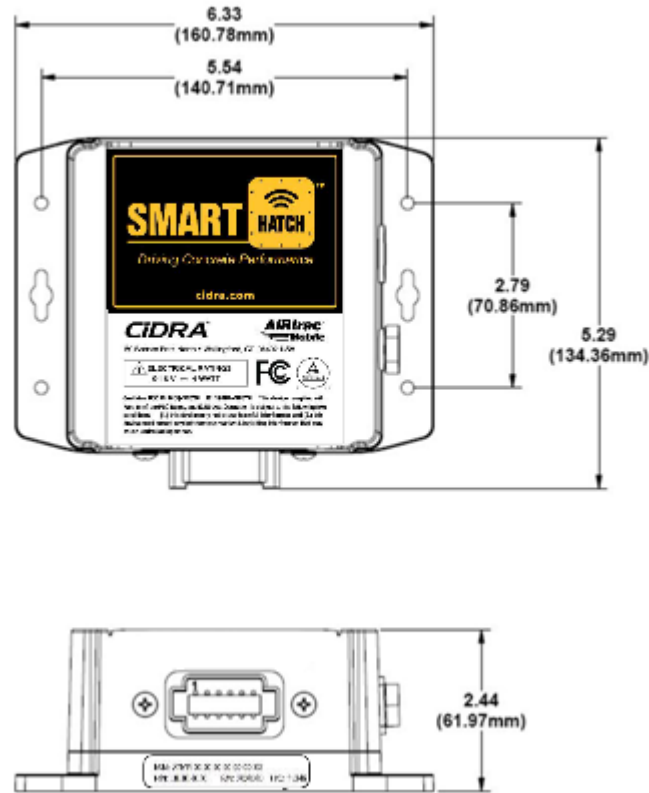

Weight: 2 lbs (0.9 kg)

# A7

# Display Dimensional Envelope (Option 1)

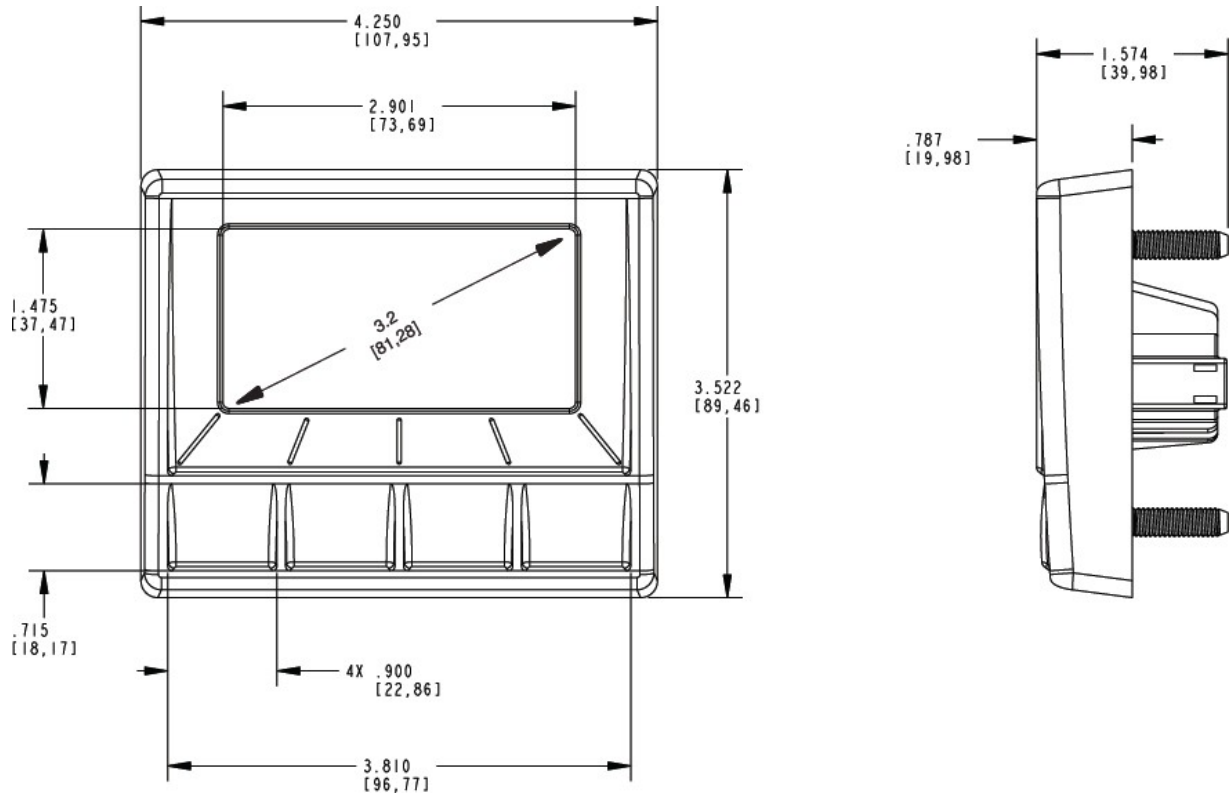

Weight: 1 lbs (0.45 kg)



## **A8 Altitude Limits**

---

The sensor, receiver module and display are rated for installations up to an altitude of 5,000m (16,404ft.).

## **A9 Humidity Limits**

---

Sensor and receiver module: 0 – 95%, non-condensing

## **A10 Degree of Protection**

---

Sensor is IP67

Receiver is NEMA 4, IP66

Display is IP20

## **A11 Pollution Degree**

---

Sensor and receiver module are rated for installations in Pollution Degree 2, / 4 environments. Display is rated to Pollution Degree 2

## **A12 Area Classification**

---

SMART*hatch*<sup>TM</sup> Mobile System is rated for use in non-hazardous areas only.

## **APPENDIX B - Installation Record**

---

<b>SMART<i>hatch</i> System Installation Record</b>		
Company Name:		
Address:		
City:	State:	Zip Code:
Facility Contact Name:	Facility Contact Phone:	Facility Contact Email:
Truck ID:		
Sensor Module S/N:		
Receiver S/N:		
Modem S/N:		
Number of Batteries:		
Number of Battery Chargers:		
Number of In-Cab Displays:		
Notes:		

## APPENDIX C – LED Status for Modes of Operation

---

### Module Status LED

#### Modes of operation:

Color	Blink Type	Status
Magenta	Solid	Boot loader started loading Linux
Blue	Solid	Connected to portal
Blue	Heartbeat	Normal Heartbeat, running but not connected to portal
Green	Flash	Programming SPU packet.
		Programming (Downloader).
Green	Solid	Completed programming through SPU.
		Programming Completed (Downloader).
Yellow	Flash	Waiting for interlocks.
		Waiting for required modules or PackageManagers.
Yellow	Solid	SPU Package Download in Progress.
Red	Flash	User intervention required.
Red	Solid	Hard Errors.
		Programming Failed (Downloader)

**GPS LED**

**Modes of operation:**

Color	Trigger Type	GPS
Green	Solid	Focused = 4 or more satellites, error calculation is less than 200 meters, and mode = 3 or more (at least 3D) XYZ
Yellow	Flash	Focused = 4 or more satellites, error calculation is less than 200 meters, and mode = 2 or more (at least 2D)
Yellow	Solid	Lock but high error
		No Lock
Red	Flash	GPS not present

**CELL LED**

**Modes of operation:**

Color	Trigger Type	CELL
Blue	Solid	Connected to Portal through CELL.
Green	Solid	Modem Manager reports the bearer is connected (a bearer is a set of network connection settings for a cell carrier). This means the cell is connected to a data connection.
Yellow	Flash	Modem Manager reports that the bearer is not connected cell signal is > 10%.
		Modem Manager reports that the bearer is connected and signal <= 10%
Yellow	Solid	Modem Manager reports that the bearer is not connected and the cell signal is <= 10%.
Red	Flash	Cell modem is not present
Red	Solid	Cell not Configured ( Profiles but none set to auto connect)
		SIM card is not inserted in the module.



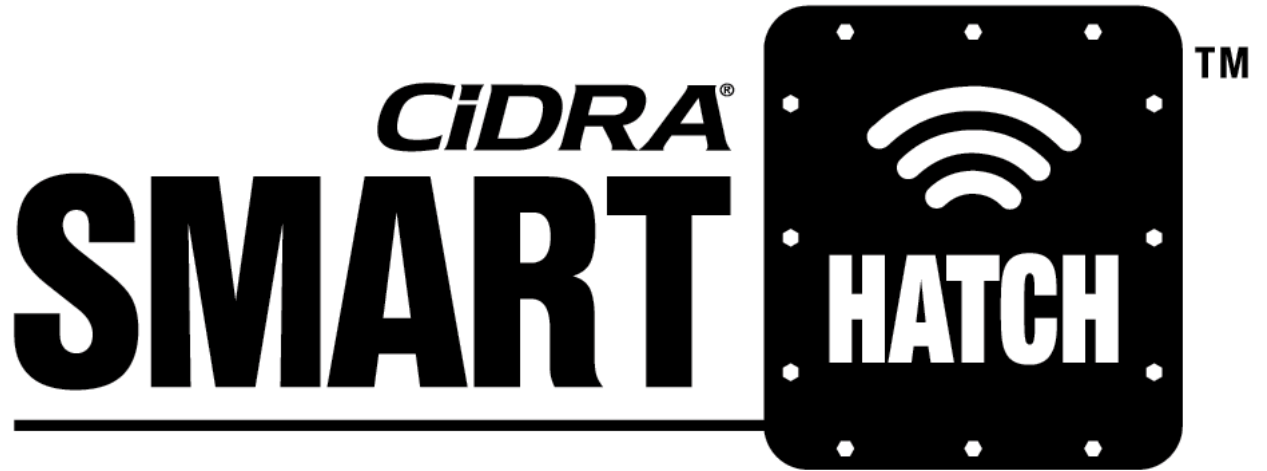

CiDRA Concrete Systems Inc.  
Tel. +1.203.265.0035

50 Barnes Park North  
Fax. +1.203.294.4211

Wallingford, CT 06492  
[www.CidraConcrete.com](http://www.CidraConcrete.com)